

Cotswold Architectural Products Ltd

Manor Park Industrial Estate
Manor Road
Cheltenham
Gloucestershire GL51 9SQ

Tel: 01242 233993 Fax: 01242 221146
e-mail: info@cotswold-windows.co.uk
website: www.cotswold-windows.co.uk



Agrément Certificate
13/4996
Product Sheet 2

COTSWOLD FRICTION HINGES

FIRE ESCAPE FRICTION STAYS

This Agrément Certificate Product Sheet⁽¹⁾ relates to Fire Escape Friction Stays for use as friction hinges for PVC-U, timber or aluminium windows to allow opening of side-hung sashes with the option of an extended opening for escape in an emergency.

(1) Hereinafter referred to as 'Certificate'.

CERTIFICATION INCLUDES:

- factors relating to compliance with Building Regulations where applicable
- factors relating to additional non-regulatory information where applicable
- independently verified technical specification
- assessment criteria and technical investigations
- design considerations
- installation guidance
- regular surveillance of production
- formal three-yearly review.



KEY FACTORS ASSESSED

Resistance to wear and fatigue — the products have sufficient resistance to wear under normal use to provide a service life consistent with that of a window (see section 5).

Resistance to mechanical loading — the product has adequate resistance to mechanical loading and will achieve the classifications shown in section 6.

Durability — the product has adequate resistance to corrosion in the conditions envisaged throughout the expected life of the windows (see section 8).

The BBA has awarded this Certificate to the company named above for the products described herein. These products have been assessed by the BBA as being fit for their intended use provided they are installed, used and maintained as set out in this Certificate.

On behalf of the British Board of Agrément

John Albon — Head of Approvals
Energy and Ventilation

Claire Curtis-Thomas
Chief Executive

Date of First issue: 28 May 2013

Certificate amended on 25 July 2013 to change year of Standard BS EN 1191 : 2000 to BS EN 1191 : 2012.

The BBA is a UKAS accredited certification body — Number 113. The schedule of the current scope of accreditation for product certification is available in pdf format via the UKAS link on the BBA website at www.bbacerts.co.uk

Readers are advised to check the validity and latest issue number of this Agrément Certificate by either referring to the BBA website or contacting the BBA direct.

British Board of Agrément
Bucknalls Lane
Watford
Herts WD25 9BA

©2013

tel: 01923 665300
fax: 01923 665301
e-mail: mail@bba.star.co.uk
website: www.bbacerts.co.uk

Regulations

In the opinion of the BBA, Fire Escape Friction Stays, if installed, used and maintained in accordance with this Certificate, will meet or contribute to meeting the relevant requirements of the following Building Regulations (the presence of a UK map indicates that the subject is related to the Building Regulations in the region or regions of the UK depicted):



The Building Regulations 2010 (England and Wales) (as amended)

Requirement:	B1	Means of warning and escape
Comment:		The products can contribute to meeting this Requirement. See section 4.2 of this Certificate.
Regulation:	7	Materials and workmanship
Comment:		The products are acceptable. See section 8.2 and the <i>Installation</i> part of this Certificate.



The Building (Scotland) Regulations 2004 (as amended)

Regulation:	2.9	Escape
Comment:		The products can contribute to meeting this Regulation with reference to clause 2.9.4 ⁽¹⁾ . See section 4.2 of this Certificate.
Regulation:	8(1)(2)	Fitness and durability of materials and workmanship
Comment:		The products satisfy the requirements of this Regulation. See sections 7.1 and 8.2 and the <i>Installation</i> part of this Certificate. (1) Technical Handbook (Domestic).



The Building Regulations (Northern Ireland) 2012

Regulation:	23(a)(i)(iii)(b)(i)	Fitness of materials and workmanship
Comment:		The products are acceptable. See section 8.2 and the <i>Installation</i> part of this Certificate.
Regulation:	33(c)	Means of escape
Comment:		The products can contribute to meeting this Regulation. See section 4.2 of this Certificate.

Construction (Design and Management) Regulations 2007

Construction (Design and Management) Regulations (Northern Ireland) 2007

In the opinion of the BBA, there is no information in this Certificate which relates to the obligations of the client, CDM co-ordinator, designer and contractors under these Regulations.

Additional Information

NHBC Standards 2013

NHBC accepts the use of Fire Escape Friction Stays, provided they are installed, used and maintained in accordance with this Certificate in relation to *NHBC Standards, Chapter 6.7 Doors, windows and glazing*.

Technical Specification

1 Description

1.1 The metallic components of Fire Escape Friction Stays (see Figure 1) are made from stainless steel, numbers 1.4016 (ferretic) or 1.4301 (austenitic) to BS EN 10088-2 : 2005.

1.2 Fire Escape Friction Stays are available for side-hung casement windows and feature green coloured slider and end caps for emergency egress identification and purple coloured slider sections for easy-clean identification.

1.3 The SP316 and SP254 Fire Escape Friction Stays allow windows to open to their maximum opening angle (shown in Table 1) for full egress providing clearance for fire escape and feature green coloured slider and end caps for emergency egress identification.

1.4 The SP350 product will allow full opening of the window for an easy-clean position and feature green coloured slider and end caps for emergency egress identification. In an emergency, a firm blow to the centre of the window sash releases a male and female jigsaw egress release and allows the window to be opened to the maximum opening angle (shown in Table 1) for full egress providing clearance for fire escape.

1.5 The SP312EZ and SP316EZ Fire Escape Friction Stays feature black coloured sliders and end caps and will allow full opening of the window for egress providing clearance for fire escape (see Table 1). Depressing and sliding the purple easy-clean button after partially closing the window and pushing out the handle will slide the window into the easy-clean position. The purple sliding button resets into the egress position after closing the window.

Figure 1 Typical Fire Escape Friction Stay

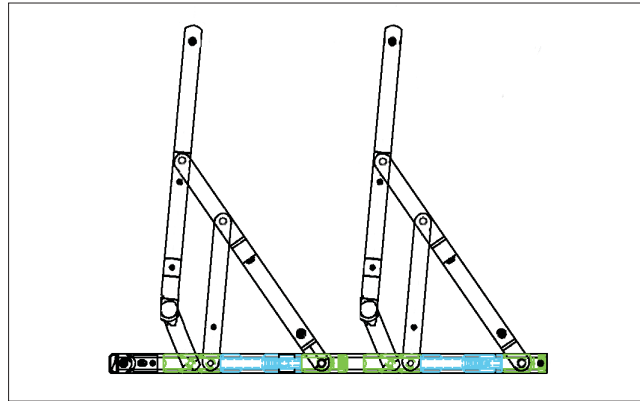

Table 1 Fire Escape Friction Stay ranges

Product code	Size (inches)	Maximum opening angle (°)	Maximum sash weight (kg)	Maximum sash height (mm)	Maximum sash width (mm)
SP254	10	80 ⁽¹⁾	21	1200	600
SP312EZ	12	85 ⁽¹⁾	18	1200	600
SP350-H	14	88 ⁽¹⁾	21	1300	650
SP316	16	84 ⁽¹⁾	21	1200	600
SP316EZ	16	84 ⁽¹⁾	21	1200	600

(1) Manufacturer's own data.

2 Manufacture

2.1 The arms of the product are fastened to the slide using rivets. The assembled slide is placed into the channel of the friction stay and an end rivet inserted.

2.2 As part of the assessment and ongoing surveillance of product quality, the BBA has:

- agreed with the manufacturer the quality control procedures and product testing to be undertaken
- assessed and agreed the quality control operated over batches of incoming materials
- monitored the production process and verified that it is in accordance with the documented process
- evaluated the process for management of nonconformities
- checked that equipment has been properly tested and calibrated
- undertaken to carry out the above measures on a regular basis through a surveillance process, to verify that the specifications and quality control operated by the manufacturer are being maintained.

2.3 The management systems of Cotswold Architectural Products Ltd have been assessed and registered as meeting the requirements of BS EN ISO 9001 : 2008 by LRQA (Certificate LRQ 0880449).

3 Delivery and site handling

3.1 The products are packed in cardboard boxes, each containing 25 or 50 pairs of stays, and labelled with the BBA identification mark incorporating the number of this Certificate.

3.2 Boxes should be stored under cover in a clean area and suitably supported to avoid distortion or damage.

Assessment and Technical Investigations

The following is a summary of the technical investigations carried out on Fire Escape Friction Stays.

Design Considerations

4 Use

4.1 Fire Escape Friction Stays are suitable for use in side-hung windows made from PVC-U, timber or aluminium, within the limits shown in Table 1. Windows must have an outer frame/sash design suitable for correct fixing of the stays using appropriate screws⁽¹⁾ through the profiles or reinforcement. The Certificate holder will advise on the suitability of window profiles. It is the responsibility of the specifier to ensure that the finished window meets any required safety specifications.

(1) Outside the scope of this Certificate.



4.2 The products can be fitted to side-hung windows to have a clear opening not less than 0.33 m² to allow for emergency egress. Windows of this type shall have a clear opening at least 450 mm high and at least 450 mm wide.

4.3 The products are available in 13 mm and 17 mm stack heights to suit the design of the window system.

5 Resistance to wear and fatigue

Fire Escape Friction Stays are similar in design and mechanical operation to Extreme Friction Stays (covered by Product Sheet 4), which were tested for cyclic operation in accordance with BS EN 1191 : 2012 and exceeded Class 3 — Heavy Duty when classified to BS EN 12400 : 2002. In the opinion of the BBA, Fire Escape Friction Stays will also exceed Class 3 — Heavy Duty.

6 Resistance to mechanical loading

6.1 Selected samples from the Extreme Friction Stays range (Product Sheet 4) were tested on suitable windows in accordance with BS 6375-2 : 1987, BS 6375-2 : 2009 and BS EN 13126-6 : 2008 (see Table 2). In the opinion of the BBA, Fire Escape Friction Stays will have the same mechanical loading characteristics.

Table 2 Mechanical loading characteristics

Test method and year of standard	Extreme Friction Stays (16 inches) ⁽¹⁾
Static torsion (BS 6375-2 : 2009)	Class 3
Racking (BS 6375-2 : 2009)	Class 3
Strength of maximum opening stops (BS 6375-2 : 1987)	Pass
Pull-in test (BS EN 13126-6, clause 7.2)	Pass
Friction test (BS EN 13126-6, clause 7.3)	Pass
Obstructed stay test (BS EN 13126-6, clause 7.4)	Pass
Pull-in abuse test (BS EN 13126-6, clause 7.5)	Pass
Static load (BS EN 13126-6, clause 7.9)	Pass
Additional load (BS EN 13126-6, clause 7.10)	Pass

(1) Weight of tested sash 35 kg, height of sash 1300 mm.

6.2 If classification of mechanical strength of a particular window is required, the window itself should be tested in accordance with BS 6375-2 : 2009.

7 Maintenance



7.1 The product should be cleaned and lubricated every six months to minimise wear and to ensure smooth operation. Care should be taken to avoid applying lubricant to the sliders as this will impair their braking action.

7.2 If damage occurs, the product can be replaced by removing the fixing screws and replacing the hinge.

8 Durability

8.1 Extreme Friction Stays (Product Sheet 4) were tested for resistance to salt spray as defined in BS EN 1670 : 2007 and achieved Grade 4 — Very high corrosion resistance. In the opinion of the BBA, Fire Escape Friction Stays will also achieve Grade 4.



8.2 The products are constructed from durable materials and, when installed in accordance with this Certificate, will last the expected life of the window. Where windows are to be installed in areas subject to particularly corrosive conditions (such as coastal locations or near sources of industrial pollutants), friction stays made from stainless steel number 1.4301 (austenitic) should be used.

8.3 The products may need to be replaced within the life of a window if they become damaged.

9 Reuse and recyclability

The products comprise either ferretic or austenitic stainless steel, which can be recycled.

Installation

10 General

10.1 Installation of Fire Escape Friction Stays must be carried out in accordance with the Certificate holder's instructions using suitable corrosion resistant screws⁽¹⁾.

(1) Outside the scope of this Certificate.

10.2 The correct size of product should be chosen to suit the sash weight and height/width.

11 Procedure

The products are screwed first to the window sash, and then to the outer frame.

12 Tests

Tests were carried out on stays similar to Fire Escape Friction Stays to determine:

- cyclic operation in accordance with BS EN 1191 : 2012
- mechanical loading in accordance with BS 6375-2 : 1987, BS 6375-2 : 2009 and BS EN 13126-6 : 2008
- resistance to salt spray in accordance with BS EN 1670 : 2007.

13 Investigations

13.1 An assessment was made of the durability of the components used in the manufacture of the products.

13.2 The manufacturing process was evaluated, including the methods adopted for quality control, and details were obtained of the quality and compositions of materials used.

Bibliography

- BS 6375-2 : 1987 *Performance of windows — Specification for operation and strength characteristics*
BS 6375-2 : 2009 *Performance of windows and doors — Classification for operation and strength characteristics and guidance on selection and specification*
BS 8213-1 : 2004 *Windows, doors and rooflights — Design for safety in use and during cleaning of windows, including door-height windows and roof windows — Code of practice*
BS EN 1191: 2012 *Windows and doors — Resistance to repeated opening and closing — Test method*
BS EN 1670 : 2007 *Building hardware — Corrosion resistance — Requirements and test methods*
BS EN 10088-2 : 2005 *Stainless steels — Technical delivery conditions for sheet/plate and strip of corrosion resisting steels for general purposes*
BS EN 12400 : 2002 *Windows and pedestrian doors — Mechanical durability — Requirements and classification*
BS EN 13126-6 : 2008 *Building hardware — Requirements and test methods for windows and doors height windows — Variable geometry stay hinges (with or without a friction stay)*
BS EN ISO 9001 : 2008 *Quality management systems — Requirements*

14 Conditions

14.1 This Certificate:

- relates only to the product/system that is named and described on the front page
- is issued only to the company, firm, organisation or person named on the front page — no other company, firm, organisation or person may hold or claim that this Certificate has been issued to them
- is valid only within the UK
- has to be read, considered and used as a whole document — it may be misleading and will be incomplete to be selective
- is copyright of the BBA
- is subject to English Law.

14.2 Publications, documents, specifications, legislation, regulations, standards and the like referenced in this Certificate are those that were current and/or deemed relevant by the BBA at the date of issue or reissue of this Certificate.

14.3 This Certificate will remain valid for an unlimited period provided that the product/system and its manufacture and/or fabrication, including all related and relevant parts and processes thereof:

- are maintained at or above the levels which have been assessed and found to be satisfactory by the BBA
- continue to be checked as and when deemed appropriate by the BBA under arrangements that it will determine
- are reviewed by the BBA as and when it considers appropriate.

14.4 The BBA has used due skill, care and diligence in preparing this Certificate, but no warranty is provided.

14.5 In issuing this Certificate, the BBA is not responsible and is excluded from any liability to any company, firm, organisation or person, for any matters arising directly or indirectly from:

- the presence or absence of any patent, intellectual property or similar rights subsisting in the product/system or any other product/system
- the right of the Certificate holder to manufacture, supply, install, maintain or market the product/system
- actual installations of the product/system, including their nature, design, methods, performance, workmanship and maintenance
- any works and constructions in which the product/system is installed, including their nature, design, methods, performance, workmanship and maintenance
- any loss or damage, including personal injury, howsoever caused by the product/system, including its manufacture, supply, installation, use, maintenance and removal
- any claims by the manufacturer relating to CE marking.

14.6 Any information relating to the manufacture, supply, installation, use, maintenance and removal of this product/system which is contained or referred to in this Certificate is the minimum required to be met when the product/system is manufactured, supplied, installed, used, maintained and removed. It does not purport in any way to restate the requirements of the Health and Safety at Work etc. Act 1974, or of any other statutory, common law or other duty which may exist at the date of issue or reissue of this Certificate; nor is conformity with such information to be taken as satisfying the requirements of the 1974 Act or of any statutory, common law or other duty of care.